

INSTRUCTION MANUAL

WSP-DSW WSP-DEW

ISOLATION CONVERTER (DUAL OUTPUT) HIGH-RESPONSE ISOLATOR (DUAL OUTPUT)

Thank you for selecting another fine *watanabe* product. Please check the description given on the rating label of this unit to make sure that it meets your specifications and be sure to read this instruction manual before using the product.

This manual outlines the operation, connection and adjustment procedures of this product.

The unit has been manufactured and inspected according to our strict quality control standard. If you should find a defect including damage incurred during transportation, contact us or the dealer where you purchased it immediately.

PACKAGE INCLUDES:

- Isolation converter.....1
- Base socket.....1

* For details of models and specifications, please download the specification sheet from our website, and then check it.

1. PRECAUTIONS

1) Conformity with CE directive

- This equipment is compliant with Installation Category II and Pollution Degree 2 environment. The insulation capability between signal input and output 1 or 2 is basic insulation. Before installing, please check that the insulation class of this equipment satisfies your system requirements.
- Please be sure to install this equipment to the inside of a panel.
- Please use this equipment at an altitude of up to 2000 m.
- Compliance with EN standards:
 - EN61326-1 EMS: Industrial environments; EMI: Class A
 - EN61010-1 The wiring length should be not more than 30 m.
 - EN50581
- * Custom-made items other than a catalog standard specification are outside CE conformity.

2) Power supply

- Check the rated voltage on the rating label, and use the product within the range of each of the following ratings (Δ is indicated on the rating label.)
 - 100 to 240VAC
100 to 240VAC $\pm 10\%$ (50/60 Hz) approx. 4.4 VA
 - 24VDC
24VDC $\pm 10\%$ approx. 100 mA
* You can use it as 10.8 to 30 V, if you do not use this product as a CE compliant article.
 - 110VDC
110VDC $\pm 10\%$ approx. 16 mA

3) Handling

- When removing or mounting the main body from/to the socket, be sure to turn OFF the power supply and the input signal in advance to prevent any problems.

4) Installation

- This equipment is designed for indoor use.
- Please install the main body in a location where the ambient temperature is within -5 to 55°C.
- Please install the main body in a location where relative humidity is less than 90%RH (no freezing or condensation).
- When the equipment is to be installed in a location where there is excessive dust or metal particles, house it in a dust-proof cabinet, which has a heat radiation function.
- Avoid exposing the equipment to vibration and impact, which may cause malfunction.
- Please do not block ventilation openings of the main body.

5) Wiring

- Be sure to keep the wiring of the power line, input signal line and output signal line away from any noise source, relay driving line and high-frequency line.
- Avoid clamping these lines together with a noise-superimposed line or putting them together in the same duct.

6) Others

- This equipment can be operated as soon as the power supply is turned ON. However, for optimum performance, allow 30 minutes of energizing time.
- This product is precision equipment. It is therefore recommended that you periodically calibrate it by performing ZERO and SPAN adjustments once a year.

2. OUTLINE DIMENSIONS

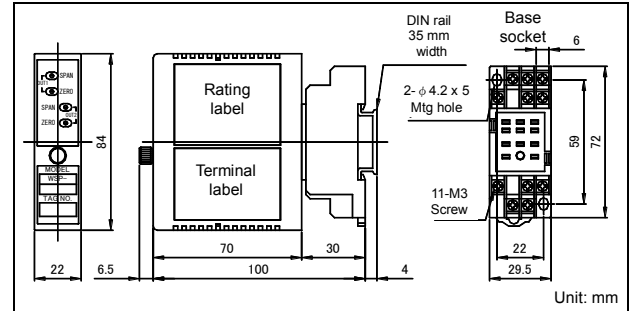

3. CIRCUIT DIAGRAM

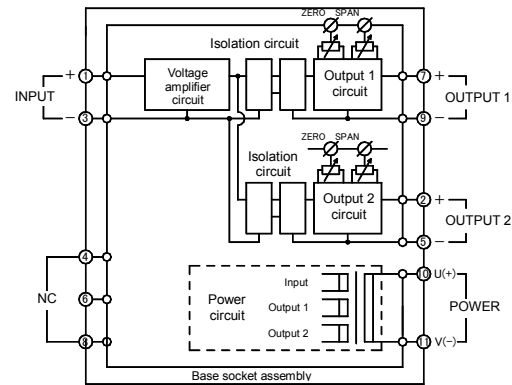

4. NAME OF EACH PART AND TERMINAL LAYOUT

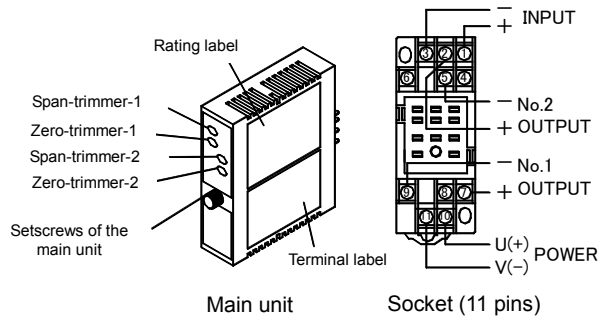

Terminal No.	Symbol	Contents
1	INPUT	Connect the specified input signal.
3		
2	No.2 OUTPUT	The signal based on the input/output specification is output.
5		
4	NC	No Connection
6	NC	No Connection
7	No.1 OUTPUT	The signal based on the input/output specification is output.
9		
8	NC	No Connection
10	POWER	Connect the power supply of the rated voltage.
11		

Connection points : M3 SEMS screw
Screw tightening torque : Recommended: 0.6 N-m

5. ADJUSTMENT

Since this equipment has been properly calibrated at the time of shipping, each trimmer of ZERO and SPAN does not require adjustment as long as the equipment is operated according to the manufacturing specifications. If matching with connected equipment or routine calibration is required, observe the following procedures.

This calibration shall be made 30 minutes after the power supply is turned ON, using a signal source (such as standard voltage, current generator), and measuring instruments (voltmeter, ammeter), whose accuracies are 10 times or higher than that of this equipment. The ZERO and SPAN adjustment ranges are both about 10% fs. Multi-turn trimmers are installed for performing these adjustments.

- 1) ZERO adjustment: Apply a minimum value within the input range to the input terminals, and turn the zero-trimmer until the output signal reaches the minimum value within the output range.
- 2) SPAN adjustment: Apply a maximum value within the input range to the input terminals, and turn the span-trimmer until the output signal reaches the maximum value within the output range.

	In case of 4 to 20 (1 to 5 V) mA output	In case of 0 to 10 V output
Zero adjustment ① ZERO Shifts the zero upwards. Shifts the zero downwards.		
Span adjustment ① SPAN Widens the span. Narrows the span.		

6. Operation Against Conditions out of Range

1) Excessively large input

When a signal exceeding the upper limit of the input range is input, the output signal is increased nearly proportional to the input up to approx. 120%fs. If a greater input signal is input beyond that, the output signal won't be increased beyond approx. 120%fs.

2) Excessively small input

If a signal lower than the lower limit of the input range is input, the output operation is as follows.

- ① In the case of a current output, the output signal flows to the negative side as well. However, the negative current carrying capacity is only about 5 mA, so do not pass negative current.
- ② With the voltage output, the output signal is reduced nearly proportional to the input down to -120%fs.

3) Load out of range

- ① In the case of a current output, if the "allowable load resistance range" is exceeded, the output obtained will be roughly proportional to the input over the range to where the voltage between the output terminals at OUTPUT 1 becomes about 15 V, and the voltage at OUTPUT 2 becomes about 11 V. However, if the input exceeds this range, the output will saturate and the error will increase.
- ② In the case of voltage output, if the output is reduced below the "allowable load resistance range", the output will saturate and the error will increase.

7. INSTALATION DIMENSIONS

When mounting the product on a wall, refer to the installation dimension diagram.

The diagram below shows the minimum mounting clearance between adjacent units.

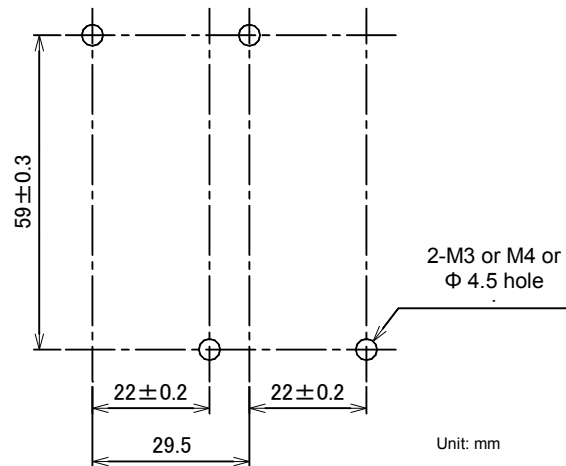

8. Mounting and Removing to/from the DIN Rail

1) How to fix the socket

Hold the product with the slider at the bottom of the socket facing downward, engage the tab at the top of the rear surface of the socket with the rail, and then push in the bottom of the socket in the direction of the arrow to fix the product in place.

2) How to fix the main body to the socket

Hold the main unit in the direction such that the text on the label can be read correctly, insert it perfectly straight, and then tighten the screws on the front of the main unit. Be careful not to tighten the screws too hard.

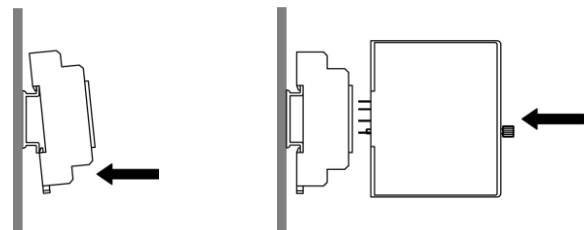

3) How to remove the main body from the socket

Slacken the screws on the front of the main unit, and withdraw the main unit perfectly straight.

4) How to remove the socket

Insert a screwdriver in the slider groove of the socket. While pulling the screwdriver in the direction of the arrow as shown in Figure ①, draw the lower part of the socket forward ② until it is removed.

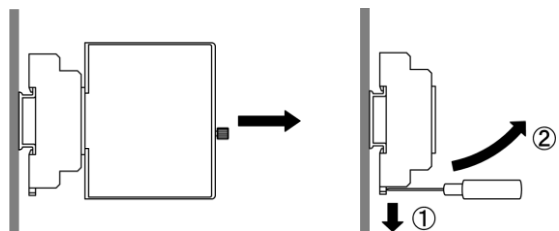

9. WARRANTY

The warranty period for this equipment is five (5) years after delivery. If it should fail under the normal operation conditions within the warranty period, contact us or the dealer where you purchased the equipment as soon as possible.

We will repair the defective equipment free of charge or replace it with a new one if necessary. This warranty does not apply to equipment damaged due to disassembly, modifications or operation under conditions other than those specified.

We will not take any responsibility for any damage incurred due to this product.